

MODELS:

RHEP2S5020N	RHEP2S8030N	RHEP2S15540N	RHEP2S20560N
RHEP2S5030N	RHEP2S11530N	RHEP2S15550N	RHEP2S22560N
RHEP2S6520N	RHEP2S11540N	RHEP2S18050N	RHEP2S22570N
RHEP2S6530N	RHEP2S13030N	RHEP2S18060N	RHEP2S25060N
RHEP2S8020N	RHEP2S13040N	RHEP2S20550N	RHEP2S25070N

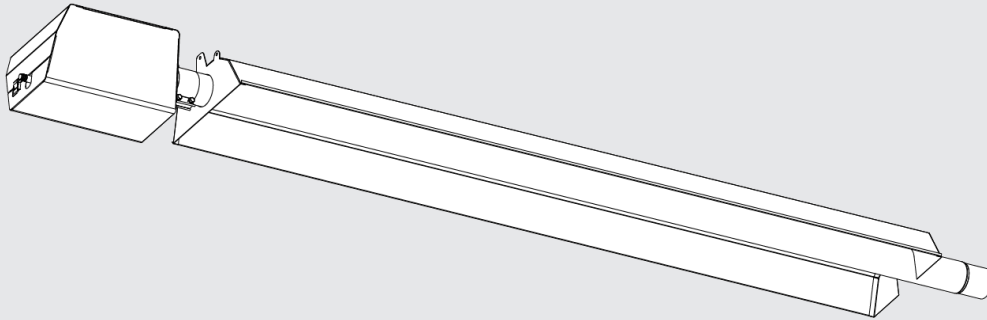

## High-Efficiency (HE+) Series Infrared Gas Heater 2-Stage Supplemental Manual

**Rinnai®**

**LOW INTENSITY TUBE TYPE INFRARED HEATER  
WITH HIGH EFFICIENCY EC Motor**

**ANSI Z83.20-2016 • CSA 2.34-2016**

**NOTICE:**

*This manual is current and correct for this product at time of manufacture. Occasional revision of the product Certification Standard may require changes to the product and/or this manual. This publication, or parts thereof, may not be reproduced in any form, without prior written consent from Rinnai. Unauthorized use or distribution of this publication is strictly prohibited.*



**TWO STAGE — SUPPLEMENTARY MANUAL**  
**A GENERAL INFORMATION MANUAL IS INCLUDED IN THE BURNER KIT**



**WARNING** Improper installation, adjustment, alteration, service or maintenance can cause property damage, injury or death. Read the installation, operating and maintenance instructions thoroughly before installing or servicing this heater.



**SAFETY ALERT:**

Do not store or use gasoline or other flammable vapours and liquids in the vicinity of this or any other gas fired appliance.



**IF YOU SMELL GAS:**

- Extinguish any open flame
- Do not attempt to light this or any other appliance
- Don't touch any electrical switch, or telephone
- Immediately call your gas supplier from a neighbor's phone
- Follow any and all instruction from your gas supplier
- If your gas supplier is not available, call the fire department



**FIELD CONVERTIBILITY:**

This appliance is field convertible to LP gas.  
Only use a kit available from Rinnai.  
Follow instructions provided in the kit and all local and national codes.

**Keep this manual in a secure place.**

Record for future reference:

Model #: \_\_\_\_\_

Serial #: \_\_\_\_\_

# HE+ SERIES: TWO-STAGE MODELS

- ALSO REFER TO THE GENERAL MANUAL INCLUDED FOR THIS SERIES HEATER

<b><u>THIS SUPPLEMENTARY MANUAL: TABLE OF CONTENTS</u></b>			
TOPIC	..... PAGE	TOPIC	.....PAGE
<b>APPLICATION</b>	4	8B. WIRING DIAGRAM: MULTIPLE	
1. INPUT RATINGS AND DIMENSIONS	5	HEATERS PER THERMOSTAT	22
2. BURNER / TUBE KIT ASSEMBLY CHART	7	9. FENWAL DSI: SEQUENCE OF OPERATION	23
3. TURBULATOR LENGTH & LOCATION	11	SPARK IGNITER SET UP	25
4. COMBUSTION AIR DUCTING	13	FENWAL DSI SERVICE CHECK	25
5. FLUE VENTING:	14	10. TROUBLESHOOTING GUIDE: DSI	26
MIN./MAX. SYSTEM LENGTHS	15	11. TROUBLESHOOTING GUIDE: HEATER	27
HEATER EXPANSION & VENT	16	12. START- UP / COMMISSIONING SHEET	29
VERTICAL VENTING—CATEGORY I	17	13. GAS CONVERSION OF BURNER	31
HORIZONTAL VENTING—CATEGORY III	18	14. HIGH ALTITUDE & ORIFICE CHART	32 - 33
6. GAS SUPPLY PRESSURES	20	15. BURNER PARTS LIST	34
7. ELECTRICAL AND THERMOSTAT	20	16. TUBE SYSTEM PARTS LIST	36
8A. WIRING DIAGRAM: FENWAL DSI			
24V or 120V THERMOSTAT	21		

<b><u>GENERAL MANUAL: TABLE OF CONTENTS</u></b>			
TOPIC	..... PAGE	TOPIC	.....PAGE
 <b>IMPORTANT INFORMATION - READ FIRST</b>		7. SYSTEMS WITH 90° & 180° ELBOWS	12
<b>APPLICATION</b>	4	ELBOW KIT DIMENSIONS	13
<b>HEATER EXPANSION</b>	5, 31	8. SUSPENSION OF THE SYSTEM	14
<b>GAS CONNECTION</b>	5, 31	9. BURNER & TUBE INSTALLATION:	
<b>VENTING</b>	5, 26	STRAIGHT TUBE SYSTEM	15
<b>START UP 'SMOKE'</b>	5	SPECIAL COUPLING - 180 to 260 Mbh	18
<b>THERMOSTAT SETTING / COMFORT</b>	5	10. SEISMIC RESTRAINT	19
<b>TUBE 'GLOW'</b>	6	HIGH WIND RESTRAINT	19
<b>CLEARANCE TO COMBUSTIBLES</b>	6	11. REFLECTOR INSTALLATION	20
Clearances Figure & Table	7	12. GAS SUPPLY	21
<b>STACKING HEIGHT SIGN</b>	8	HEATER EXPANSION	22
		FLEXIBLE GAS CONNECTION	23
1. LABOR REQUIREMENTS	9	13. ELECTRICAL AND THERMOSTAT	24
2. INSTALLATION IN AIRCRAFT HANGARS	9	14. HIGH ALTITUDE INSTALLATION	24
3. COMMERCIAL GARAGES	9	15. LIGHTING INSTRUCTIONS	24
4. USE OTHER THAN SPACE HEATING	9	16. RECOMMENDED MAINTENANCE	24
5. PRE-INSTALLATION SURVEY	10	17. OPTIONAL ACCESSORIES	25
6. MOUNTING CLEARANCES	11	OPTIONAL CONTROLS	27
SERVICE CLEARANCE	11	WARRANTY STATEMENT	BACK PAGE
HEATER PLACEMENT GUIDELINES	12		



## WARNING



Improper installation, adjustment, alteration, service or maintenance can cause property damage, injury or death. Read and understand this installation and operation manual thoroughly prior to assembly, installation, operation or service to this appliance.

This heater must be installed and serviced only by a trained gas service technician.



Do not store or use gasoline or other flammable vapours and liquids in the vicinity of this or any other gas fired appliance.

Failure to comply could result in personal injury, death, fire and/or property damage.



Do not store or use gasoline or other flammable vapours and liquids in the vicinity of this or any other gas fired appliance.

This appliance may have sharp edges and corners. Wear protective clothing such as gloves and protective eye wear when servicing this or any other appliance.

### California Proposition 65:



**WARNING:** This product can expose you to chemicals including carbon monoxide, which is known to the State of California to cause birth defects or other reproductive harm. For more information, go to [www.P65Warnings.ca.gov](http://www.P65Warnings.ca.gov)

## APPLICATION

HE+ Series models are two-stage gas-fired radiant tube heaters that may be installed for heating of commercial / industrial indoor spaces. Not for use in residential dwellings.

A “residential dwelling” is defined in the standard as “a housekeeping unit used or intended to be used as a domicile by one or more persons, containing cooking, eating, living, sleeping, and/or sanitary facilities. A residential dwelling does not include an attached garage, detached garage, workshop or outdoors”. Local Code requirements take precedence for this application.

It is beyond the scope of these instructions to consider all conditions and requirements that may be encountered in the field. Installation must conform with all local codes or, in the absence of local codes, with the latest edition of the National Fuel Gas Code, ANSI Z223.1/NFPA 54 in the U.S.A. The latest edition Electrical Code ANSI/NFPA No. 70 in the U.S.A. must also be observed.

Installation of a gas fired tube heater must conform to all heating installation design procedures including clearance to combustibles, connection to the gas and electrical supplies, and ventilation requirements.

This heater is not for installation in a Class 1 or Class 2 explosive environment, nor in a residential dwelling. If installation of this equipment is in question, consult with the local authority having jurisdiction (Fire Marshall, labor department, insurance underwriter, or other).

Revisions to codes and/or standards, may require revision to equipment and installation procedures. In case of discrepancy, the latest codes, standards, and installation manual will take priority over prior releases.

**1. TABLE 1: INPUT RATINGS (BTUH) AND DIMENSIONS**

TWO-STAGE INPUT RATE [BTUH]	FUEL TYPE	TUBE LENGTH STRAIGHT [FT]	OVERALL HEATER LENGTH [FT]	APPROX NET WEIGHT [LB]
50,000	NG / PROPANE	20	21' 7"	111
		30	31' 3"	154
65,000	NG / PROPANE	20	21' 7"	111
		30	31' 3"	154
80,000	NG / PROPANE	20	21' 7"	111
		30	31' 3"	154
115,000	NG / PROPANE	30	31' 3"	154
		40	40' 11"	197
130,000	NG / PROPANE	30	31' 3"	154
		40	40' 11"	197
155,000	NG / PROPANE	40	40' 11"	197
		50	50' 7"	239
180,000	NG / PROPANE	50	50' 7"	239
		60	60' 3"	282
205,000	NG / PROPANE	50	50' 7"	239
		60	60' 3"	282
225,000	NG / PROPANE	60	60' 3"	282
		70	69' 11"	324
250,000	NG / PROPANE	60	60' 3"	282
		70	69' 11"	324

FLEXIBLE GAS CONNECTOR (Included in Burner Kit) - MUST INSTALL - see GENERAL MANUAL Section 15

**USA - Stainless Steel Flexible Gas Connector**

205,000 or less:  
 903000013 - 1/2"x24"  
 225,000 or more:  
 903000061 - 3/4"x36"

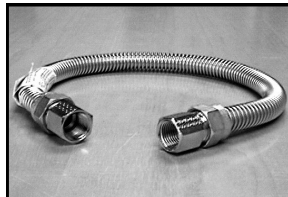

**FIGURE 1 HEATER DIMENSIONS**

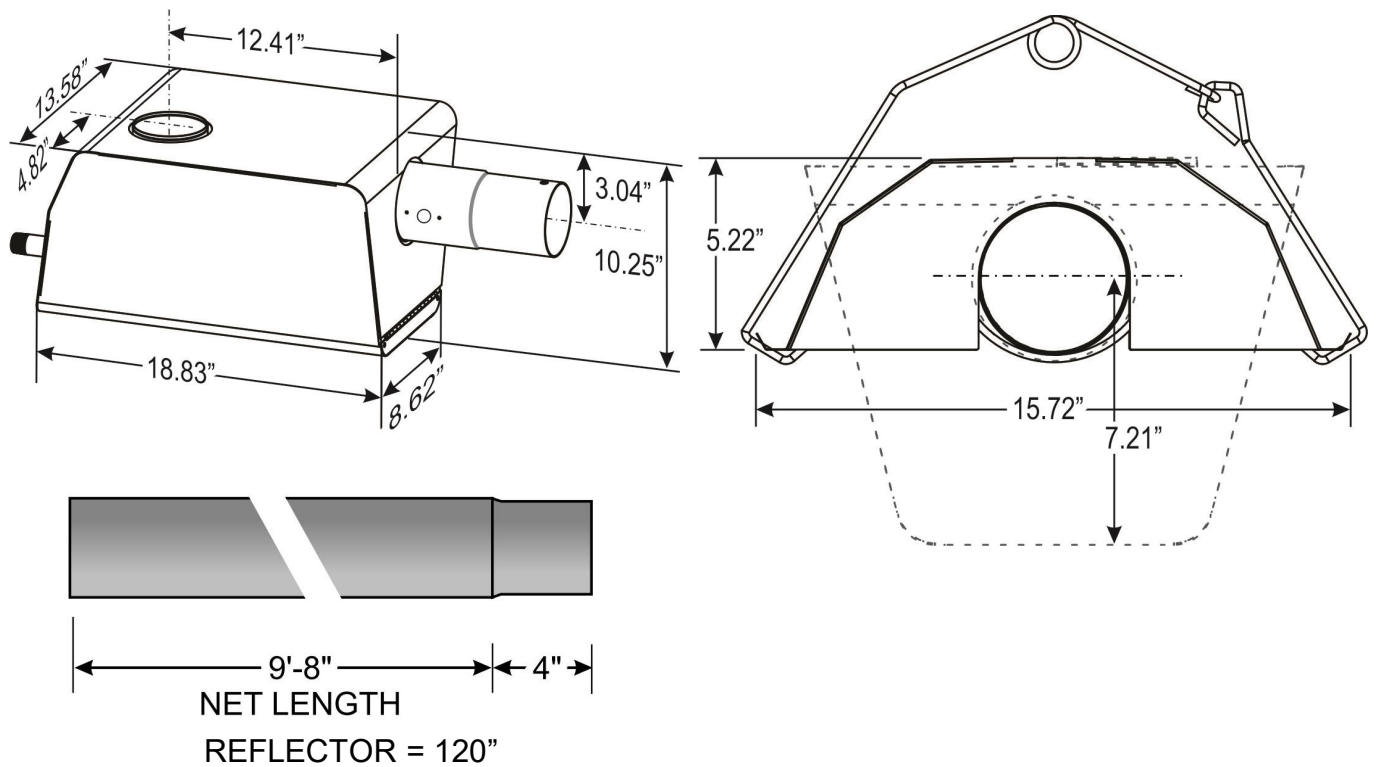

**FIGURE 2 HANGER SPACING / LENGTH - AIR INTAKE TO VENT END**

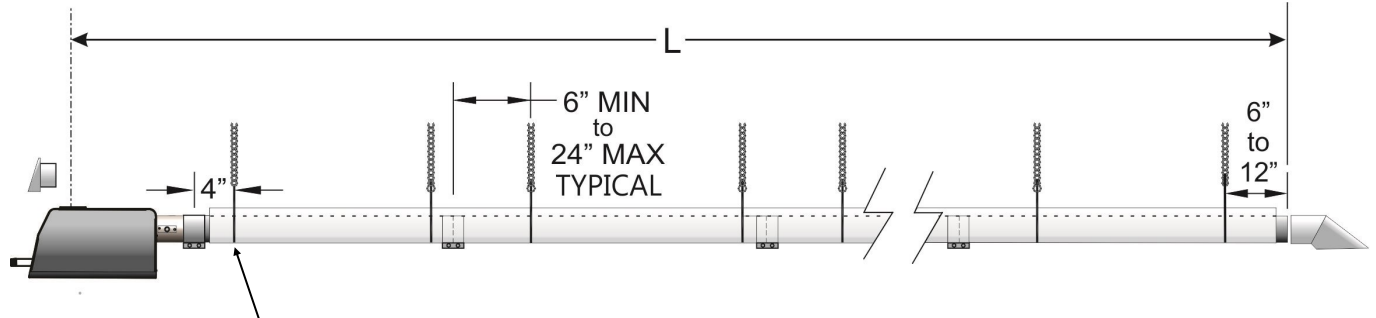

- POSITION BURNER END HANGER 4 INCHES (10 CM) FROM BURNER CONNECTION
- LOCATE SYSTEM HANGERS NO LESS THAN 6 INCHES (150mm) AND NO MORE THAN 24 INCHES (610mm) FROM TUBE COUPLING

<u>Tube Length</u>	<u>'L' = center air intake to end</u>			<u>Tube Length</u>	<u>'L' = center air intake to end</u>		
10'	11'-3 3/4"	; 135 3/4"	; 345 cm	50'	49'-11 3/4"	; 599 3/4"	; 1523 cm
20'	20'-11 3/4"	; 251 3/4"	; 628 cm	60'	59'-7 3/4"	; 715 3/4"	; 1818 cm
30'	30'-7 3/4"	; 367 3/4"	; 934 cm	70'	69'-3 3/4"	; 831 3/4"	; 2113 cm
40'	40'-3 3/4"	; 483 3/4"	; 1229 cm				

## 2. TABLE 2: HE+ SERIES TUBE KIT ASSEMBLY CHART



**BEFORE INSTALLING: ENSURE you have the CORRECT TUBE KIT(s) for the BURNER INPUT**

INPUT [BTUH]	TUBE LENGTH	BASE SYSTEM TUBE KIT(S)		FIRST TUBE	SECOND TUBE
		PRIMARY KIT	SECONDARY KIT		
50,000	20	RHEPP2AH	N/A	Aluminized Steel	Hot Rolled Steel
50,000	30	RHEPP3AH	N/A	Aluminized Steel	Hot Rolled Steel
65,000	20	RHEPP2AH	N/A	Aluminized Steel	Hot Rolled Steel
65,000	30	RHEPP3AH	N/A	Aluminized Steel	Hot Rolled Steel
80,000	20	RHEPP2AH	N/A	Aluminized Steel	Hot Rolled Steel
80,000	30	RHEPP3AH	N/A	Aluminized Steel	Hot Rolled Steel
115,000	30	RHEPP3AH	N/A	Aluminized Steel	Hot Rolled Steel
115,000	40	RHEPP4AH	N/A	Aluminized Steel	Hot Rolled Steel
130,000	30	RHEPP3AH	N/A	Aluminized Steel	Hot Rolled Steel
130,000	40	RHEPP4AH	N/A	Aluminized Steel	Hot Rolled Steel
155,000	40	RHEPP4AH	N/A	Aluminized Steel	Hot Rolled Steel
155,000	50	RHEPP3AH	RHEPS2HHS1S2	Aluminized Steel	Hot Rolled Steel
180,000	50	RHEPP3AH	RHEPS2HHS1S2	Aluminized Steel	Hot Rolled Steel
180,000	60	RHEPP3AH	RHEPS3HHS1S2	Aluminized Steel	Hot Rolled Steel
205,000	50	RHEPP3AH	RHEPS2HHS1S2	Aluminized Steel	Hot Rolled Steel
205,000	60	RHEPP3AH	RHEPS3HHS1S2	Aluminized Steel	Hot Rolled Steel
225,000	60	RHEPP4SS	RHEPS2HHS1S2	Stainless Steel	Stainless Steel
225,000	70	RHEPP4SS	RHEPS3HHS1S2	Stainless Steel	Stainless Steel
250,000	60	RHEPP4SS	RHEPS2HHS1S2	Stainless Steel	Stainless Steel
250,000	70	RHEPP4SS	RHEPS3HHS1S2	Stainless Steel	Stainless Steel

**TWO STAGE TUBE KIT SYSTEMS: INPUTS 50,000 TO 155,000 BTUH**  
**SYSTEMS FOR INPUTS 180,000 TO 250,000: NEXT PAGE**

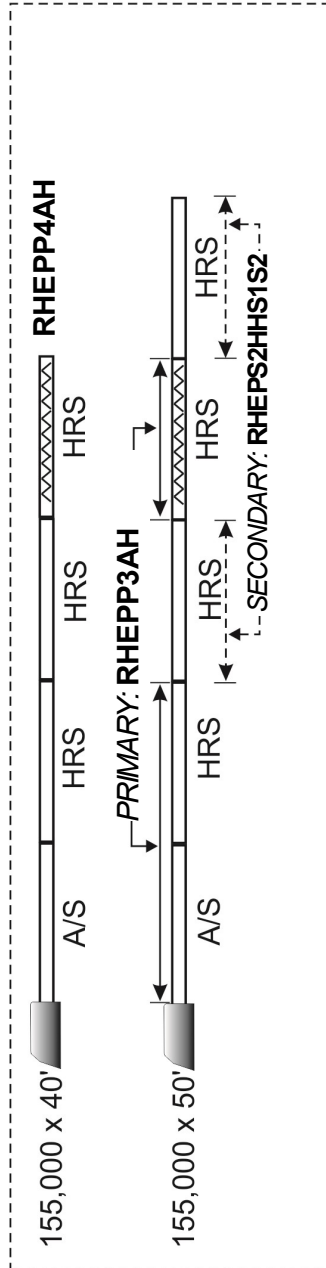
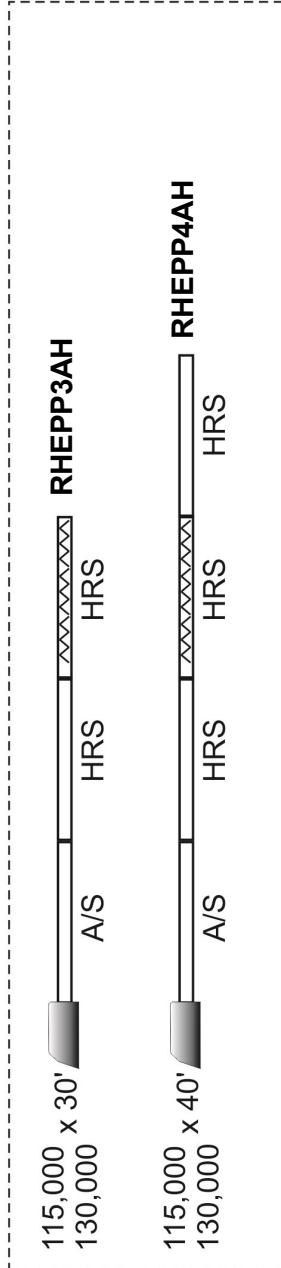
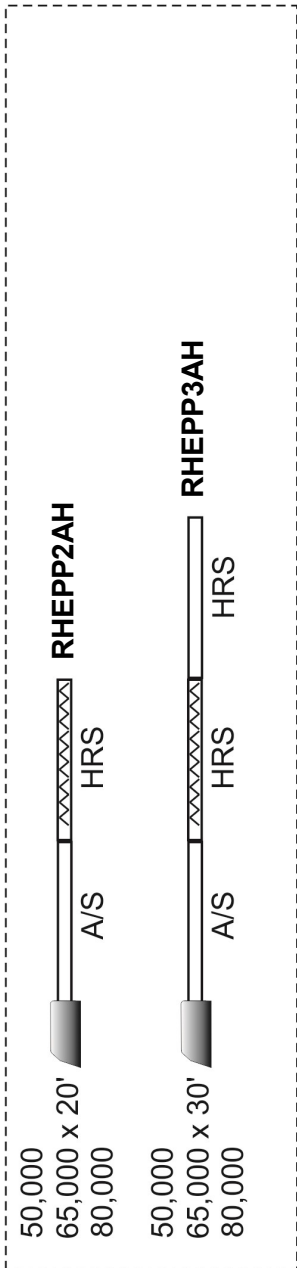

**MATERIALS LEGEND:**

- A/S = ALUMINIZED STEEL TUBE
- HRS = HOT ROLLED STEEL TUBE
- S/S = STAINLESS STEEL TUBE
- ^^ = TURBULATOR 2.25" x 36"

**TUBE KIT NOMENCLATURE**

Example: **R - HEP - P - 2 - A - H - 1S2S**

<b>R</b>	Rinnai
<b>HEP</b>	Series: High Efficiency Plus/Comfort
<b>P</b>	Type: <ul style="list-style-type: none"> <li>• P = Primary</li> <li>• S = Secondary</li> </ul>
<b>2</b>	Tube Quantity (1-4)
<b>A</b>	First Tube Material: <ul style="list-style-type: none"> <li>• A = Aluminum</li> <li>• H = Hot Rolled Steel</li> <li>• S = Stainless Steel</li> </ul>
<b>H</b>	Second Tube Material: <ul style="list-style-type: none"> <li>• A = Aluminum</li> <li>• H = Hot Rolled Steel</li> <li>• S = Stainless Steel</li> </ul>
<b>1S2S</b>	Stage <ul style="list-style-type: none"> <li>• M = Modulating</li> <li>• MX = Modulating Alternate Turbulator</li> <li>• 1S2S = 1 and 2 Stage</li> </ul>



## TWO STAGE TUBE KIT SYSTEMS: INPUTS 180,000 TO 250,000 BTUH

SYSTEMS FOR INPUTS 50,000 TO 155,000: PREVIOUS PAGE

### MATERIALS LEGEND:

A/S = ALUMINIZED STEEL TUBE

HRS = HOT ROLLED STEEL TUBE

S/S = STAINLESS STEEL TUBE

^^ = TURBULATOR 2.25" x 36"

### NOTE:

For 180 & 205 MBH models, one 36" turbulator should be removed from the tube kit. Please see next page for the turbulator removal instructions.

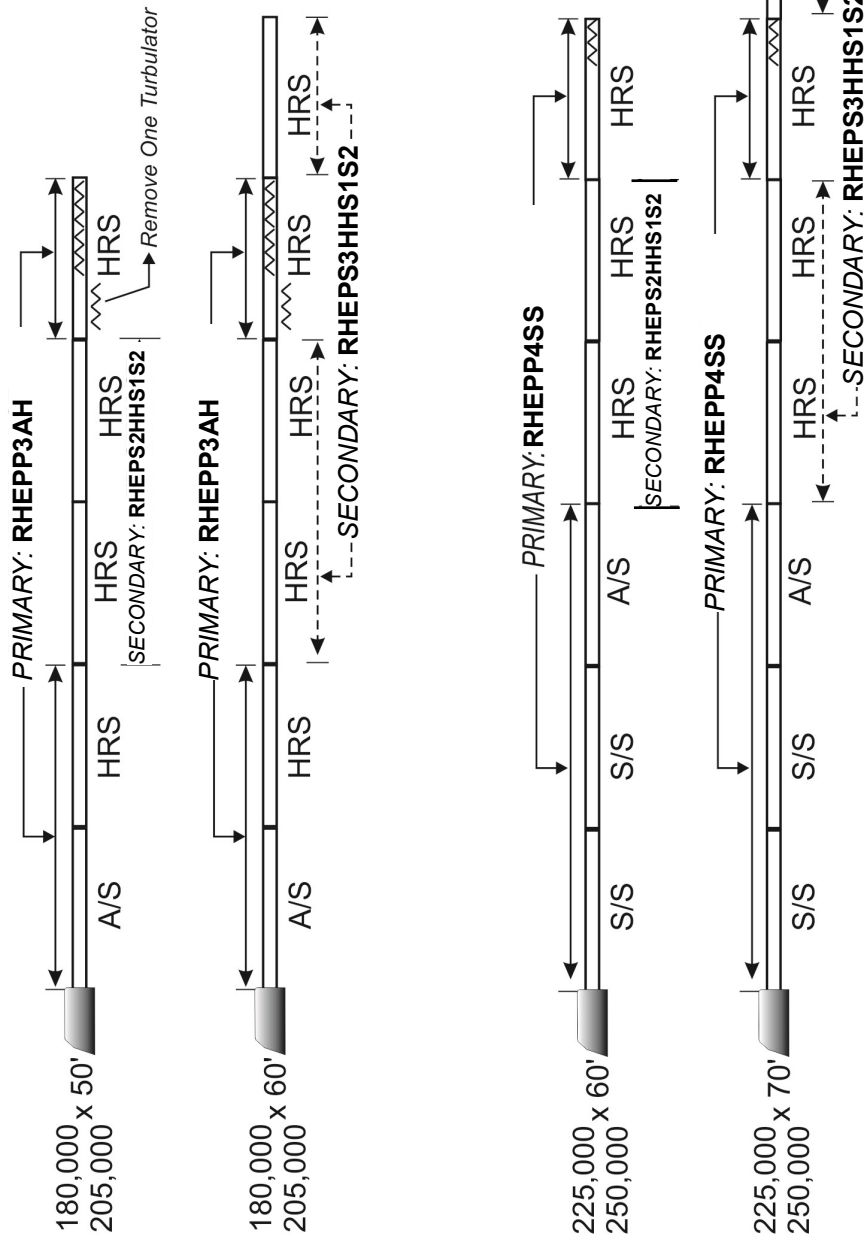

**This Page Intentionally  
Left Blank**

### 3. TURBULATOR LENGTHS & LOCATION IN SYSTEM



**NOTE:** Improper location of a turbulator can cause malfunction of the heater, property damage, and will void the heater warranty.

Tubes with turbulators inside are clearly labeled for easy identification.

ALL turbulators are located within the BASE LENGTH (shortest length) of the tube system. One or two tubes added to system base length are regular empty tubes with no turbulators. Each turbulator is 36 inches in length by 2.25" width (see Table below).

Turbulators link together with tabs, and individual sections can be removed by straightening tabs (see below). A Base Tube Kit may need turbulator removal depending on input rate (see below and illustration next page).

The orientation of the turbulator(s) [up - down; sideways] in the tube does not matter.

**TABLE 3: TURBULATORS: QUANTITY AND LOCATION IN TUBE SYSTEM**

FUEL TYPE	MODEL Input x Base Length (FT)	TURBULATOR [QUANTITY] x WIDTH x LENGTH	TURBULATOR LOCATION IN BASE LENGTH	INSTALLER ACTION REQUIRED: REMOVE & DISCARD TURBULATOR SECTION
NG or LP	50,000 x 20	[3] x 2.25" x 36"	3 IN 2nd TUBE	No action required
NG or LP	65,000 x 20	[3] x 2.25" x 36"	3 IN 2nd TUBE	No action required
NG or LP	80,000 x 20	[3] x 2.25" x 36"	3 IN 2nd TUBE	No action required
NG or LP	115,000 x 30	[3] x 2.25" x 36"	3 IN 3rd TUBE	No action required
NG or LP	130,000 x 30	[3] x 2.25" x 36"	3 IN 3rd TUBE	No action required
NG or LP	155,000 x 40	[3] x 2.25" x 36"	3 IN 4th TUBE	No action required
NG or LP	180,000 x 50	[2] x 2.25" x 36"	2 IN 5th TUBE	Remove 1 turbulator from 5th tube
NG or LP	205,000 x 50	[2] x 2.25" x 36"	2 IN 5th TUBE	Remove 1 turbulator from 5th tube
NG or LP	225,000 x 60	[1] x 2.25" x 36"	1 IN 6th TUBE	No action required
NG or LP	250,000 x 60	[1] x 2.25" x 36"	1 IN 6th TUBE	No action required

#### TURBULATOR SECTION REMOVAL: Models: 180,000 & 205,000 BTUH

1. Carefully pull out the turbulator section to be removed from the swaged end of the tube. The end of the turbulator to be left inside the tube should not extend beyond the swaged portion of the tube. Rotate the tube to have access to the locking tab

2. Bend and push the outer tab with pliers until it is in the vertical position

3. Lift up the end of the turbulator that is left inside the tube to disengage the tab that was bent in the vertical position

4. While still holding the inner turbulator in its location, pull the outer turbulator to completely disengage and discard

**FIGURE 3**



# TURBULATORS: LOCATION IN BASE SYSTEM TUBE KITS

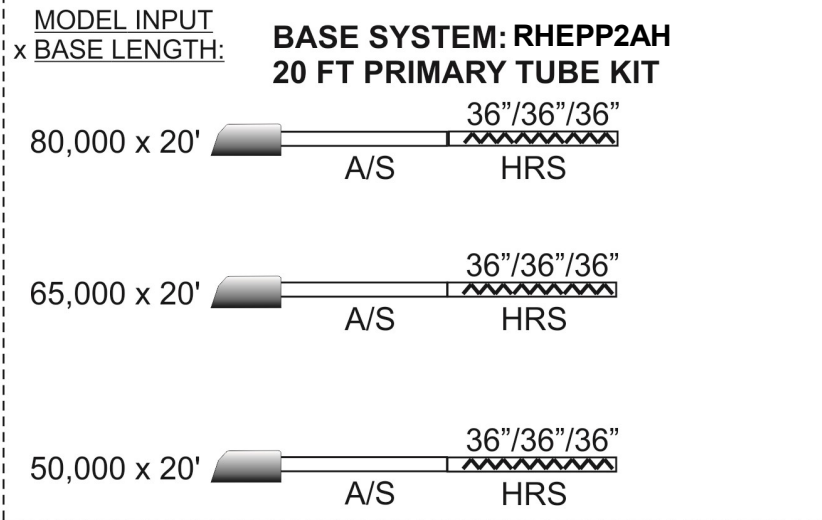

## MATERIALS LEGEND:

A/S = ALUMINIZED STEEL TUBE  
HRS = HOT ROLLED STEEL TUBE  
S/S = STAINLESS STEEL TUBE

~ = TURBULATOR 2.25" x 36"

## NOTE:

Turbulators are located within the 'Base Length' of the system. Secondary tube kits can be added to increase system length. Refer to Tube Kit section.

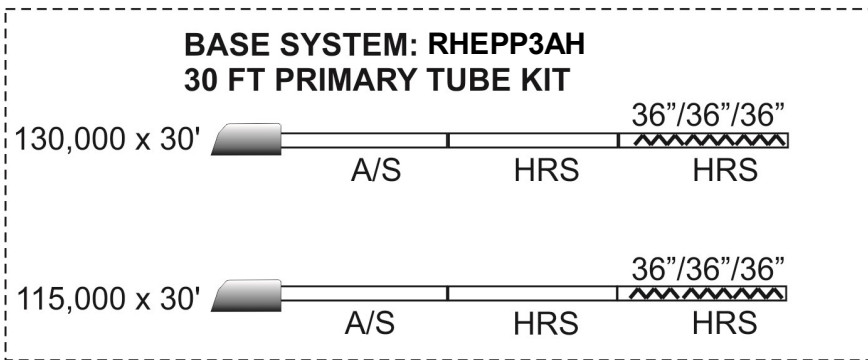

## BASE SYSTEM: RHEPP4AH: 40 FT PRIMARY TUBE KIT

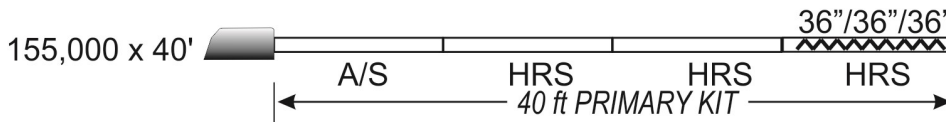

## BASE SYSTEM: RHEPP3AH + RHEPS2HHS1S2

30 FT PRIMARY + 20 FT SECONDARY TUBE KIT

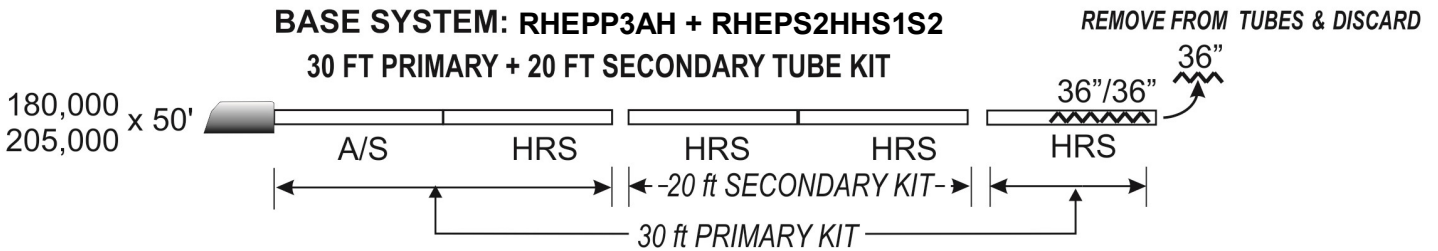

## BASE SYSTEM: RHEPP4SS + RHEPS2HHS1S2

40 FT PRIMARY + 20 FT SECONDARY TUBE KIT

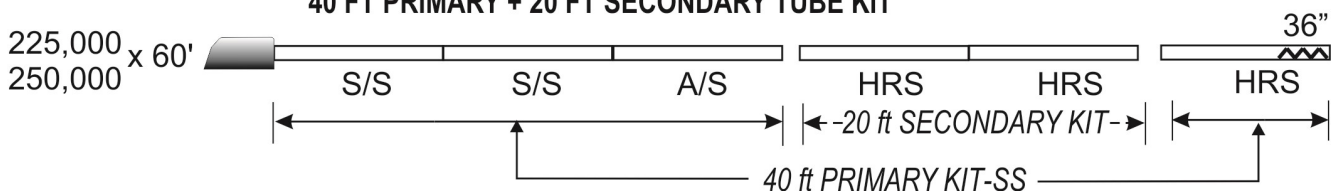

#### 4. COMBUSTION AIR DUCTING

Do not install filters on the combustion air intake. Ensure adequate clearance around the air intake to allow sufficient combustion air supply to the burner.

Air duct is typically 4" diameter, but inputs 205,000 and greater require a minimum 5" diameter duct (reduce to 4" at burner connection). Any 4" duct can be increased to 5" diameter to allow up to an additional 20 feet of duct length.

Combustion air duct must be constructed of noncombustible material. Do not use a 'soft wall' flexible hose for air duct, the corrugated sides of this tubing will contract and restrict air flow. A good quality industry approved hard-wall flex is allowed.

When a tube heater is operated in a negative air condition or air-borne dust or contaminants are present as in woodworking, and welding shops, air for combustion must be ducted from outside the negative or contaminated area to the 4 inch (10 cm) diameter intake flange supplied on the blower. Maximum system, vent and duct length is listed above.

- Do not exceed lengths listed above for total system and individual vent or air duct
- Total combined system length is reduced by five feet for every 90° elbow installed in the vent or duct *and* in the tube system (see above for allowable total lengths)
- Exceeding the allowable lengths may create condensation or soot conditions and will void product certification and warranty

The air intake will not be located less than:

- Three feet above grade
- Twelve inches from flue vent terminal of any heater with input up to 100,000 Btu/hr
- Three feet from flue vent terminal of any heater over 100,000 Btu/hr

An optional horizontal fresh air intake hood (908000021) is available to bring combustion air to the heater from an outside wall. If dropping air duct down from the roof, use an approved rain cap for the duct terminal. Ensure adequate clearance around the air intake to allow sufficient combustion air supply to the heater. When drawing fresh air from outside, it is recommended that any single wall pipe containing cold air be insulated to reduce condensation on the pipe surface.

**NOTE:** When outside-air duct drops down from the roof:

- Drop air duct to a Tee / drip leg to the side of the burner
- This will potentially reduce condensate and other moisture accumulation at the blower

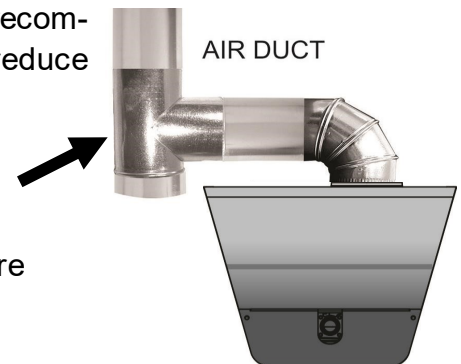

#### **CAUTION:**



In locations where chlorinated Hydrocarbons are in use, such as Trichloroethylene or Chloroethylene Nu it is essential that combustion air be brought in from a non-contaminated area. Burning the fumes from these gases will create Hydrochloric acid fumes, which are detrimental to humans, equipment and buildings. Typical sources of other contaminants are paint removers, paints, refrigerants, solvents, adhesives, degreasers, lubricants, pesticides, etc.



The heater manufacturer cannot anticipate all types nor chemical composition of potential contaminants at project sites. Prior to installation, confer with project site safety, health and engineering staff and/or local authorities having jurisdiction such as the Fire Marshall and Department of Labor for possible contaminants and any conflict with the installation of hot surface heating equipment.

## 5. FLUE VENTING - RADIANT TUBE HEATER



### IMPORTANT

**Effective immediately for this tube heater series: Changes to the ANSI/CSA standard that governs Radiant Tube Heaters specify the following appliance CATEGORIES and VENTING:**

- **Vertical Vent Through Roof (Category I):** When vented vertically, this tube heater series operates with a negative static vent pressure and a vent temperature that does not result in excessive condensate in the vent and is defined as a Category I appliance. Refer to details below.
- **Horizontal Vent Through Wall (Category III):** For horizontal vent, this tube heater series operates with a positive static vent pressure and a vent temperature that does not result in excessive condensate in the vent and is considered a Category III appliance. Refer to details below.



### WARNING

Inadequate venting of a heater may result in asphyxiation, carbon monoxide poisoning, injury or death. This heater may use a vent connection or indirect venting system to remove products of combustion from the space. Seal all vent connections with high temperature sealant. Venting must be in accordance with all local, state, provincial, and national codes (ANSI Z223.1/NFPA 54 in USA) and as indicated below in this manual.

**THIS TUBE HEATER IS CERTIFIED FOR VENTING DIRECTLY TO THE OUTSIDE OR UNVENTED (INDIRECT VENTING) APPLICATIONS.**



### UNVENTED (INDIRECT MECHANICAL VENTING SYSTEM)

**USA:** Natural or mechanical means shall be provided to supply and exhaust at least 4ft<sup>3</sup>/min/1000Btuh (0.38m<sup>3</sup>/min/kW) input of installed heaters. Some local codes may require an electrical interlock to a dedicated exhaust fan. Exhaust must be located as high as practicable in the structure above the level of the heater(s). Consult your local code and ANSI Z223.1 latest edition for all venting requirements and practices.

## VENTED TO THE OUTSIDE - GENERAL REQUIREMENTS

It is the responsibility of the installer to adhere to these instructions and all current local codes and/or ANSI Z223.1 (NFPA 54) latest editions for all venting requirements, and practices. All vent pipe will be certified to meet Category I (vertical vent) or Category III (horizontal vent) appliance requirements, depending on the vent configuration of a particular installation.

It is a normal condition that during heat-up and cool-down a tube heater will expand and contract. Allowances for heater expansion must be made in the venting and combustion air ducting. Improper installation can result in property damage, injury or death.

- When vented: The system must not be operated in a negative air condition unless combustion air is ducted from outside to the burner. If negative pressure is experienced or anticipated, the open port (barb) on each of the blocked flue and proving air switches must be Tee'd together and connected directly to outside air using a field supplied 1/4" plastic hose from the tee between the switches to outside of building.
- All approved vent pipe, connectors, and adapters are supplied locally by others according to appliance Category, and specifications below
- Do not mix vent components from different manufacturers in the vent system
- All venting must meet requirements of Local Codes or, in the absence of local codes, with the *National Fuel Gas Code*, ANSI Z223.1/NFPA 54.
- A vent connector shall comply with local codes and be firmly attached to the flue collar by 3 x

1/2" sheet metal screws

- Install a minimum 12" [305 mm] straight vent connector before any Tee or 90° Elbow
- The connection of vent components must be secured as specified in the installation instructions by the vent manufacturer.
- For vertical vent, any horizontal vent section will slope upwards away from the heater not less than 1/4 inch rise per foot of run.
- For horizontal vent, slope downward away from heater a maximum of 1/4 inch down per foot of run
- When the vent pipe passes through a cold or unheated area where the ambient temperature is likely to produce condensation of the flue gases, the vent pipe will be insulated with a suitable material as certified and specified by the insulation manufacturer to withstand temperature up to 460°F (238°C).
- The vent system must **always** be adequately supported to prevent sagging.
- The vent configuration will allow for expansion and contraction in length of the tube heater
- As an Option for vertical vent, two heaters may be vented through an approved common 4" x 4" x 6" Vent Tee (10 x 10 x 15 cm), supplied by the manufacturer, or by using approved components as indicated in local codes. Vent pipe from each heater is not required to be equidistant to the vent Tee, but must comply with local code requirements. A common thermostat or "ON/OFF" switch must control the two commonly vented heaters. Common vent is not allowed for Category III horizontal vent application.

#### **COMBINED SYSTEM LENGTH: Tube Heater + Vent + Combustion Air Duct:**

- **Refer to Table 4 next page, COMBINED SYSTEM LENGTH: TUBE + AIR DUCT + VENT.** Lengths in the table apply to either Vertical or Horizontal vent.
- **COMBINED SYSTEM LENGTH includes:** Tube Heater length + combustion air duct + vent + elbows. Each 90° elbow in the system has an equivalent length of 5 ft.
- A maximum of 2 elbows is allowed in any portion (duct, tube heater, vent) with the exception of up to three 90° elbows in a vertical vent run through the roof, for a total of maximum 6 (vertical vent: 7) 90° elbows in the combined system
- Combustion air duct is not to exceed lengths in table below and may be 4" or 5" diameter for inputs less than 200,000 Btuh, but must be 5" diameter for inputs 200,000 Btuh and greater
  - 5" diameter duct requires a reducer to 4" diameter at the connection to blower inlet
- Exceeding the allowable lengths in the table below can create combustion and/or condensation issues and will void Certification and the heater warranty.
- Do not exceed the **Maximum Combined System Length** regardless of the allowed maximum length of individual vent or combustion air duct

**TABLE 4 COMBINED SYSTEM LENGTH: TUBE + AIR DUCT + VENT**

TWO-STAGE Input (Btuh)	Do Not Exceed Maximum Combined System Length		Max. Air Duct Length (by Duct Diameter)		Max. Vent Length Individual: 4"Ø OR Combined: 6"Ø	Example
	With 4" Air Duct	With 5" Air Duct	4" Ø	5" Ø		
50,000 & 65,000	70 ft	80 ft	20 ft	30 ft	30 ft	<b>155,000 Btuh Heater:</b> Tube Heater Length      50 ft 1 x 90° elbow (vent)      5 ft Straight vent              15 ft 1 x 90° elbow (duct)      5 ft Air Duct: 4" Ø              15 ft Combined Length          90 ft Max. Allowed              90 ft Additional 10' for 5" Ø Air Duct
80,000 & 115,000	80 ft	90 ft	20 ft	30 ft	30 ft	
130,000 & 155,000	90 ft	100 ft	20 ft	30 ft	30 ft	
180,000	100 ft	110 ft	20 ft	30 ft	30 ft	
205,000	Use 5"Ø	110 ft	Use 5"Ø	30 ft	30 ft	
225,000 to 250,000	Use 5"Ø	120 ft	Use 5"Ø	30 ft	30 ft	

**HEATER EXPANSION AND VENT CONFIGURATION**

A radiant tube heater will expand and contract as it heats and cools. Configuration of the vent must allow for heater expansion.

**VERTICAL VENT:** Orientation of the vent at 90° to heater will allow for heater expansion and contraction.

**HORIZONTAL VENT:** (See FIG. 6)

- Wall Thimble or flashing at wall that allows movement of the vent through the opening. Do not seal the vent to the thimble or flashing with caulking

OR

- Offset vent with two x 90° elbows. Install minimum 12 inch [305 mm] length of straight vent between elbows. Vent can be sealed with caulking at non-combustible wall.
- Other means of slip fit installation of the vent are acceptable providing there is adequate allowance for free expansion and contraction of the system, and free flow of vent gases.

**FIGURE 6: ALLOW FOR HEATER EXPANSION - HORIZONTAL VENT - TOP VIEW**

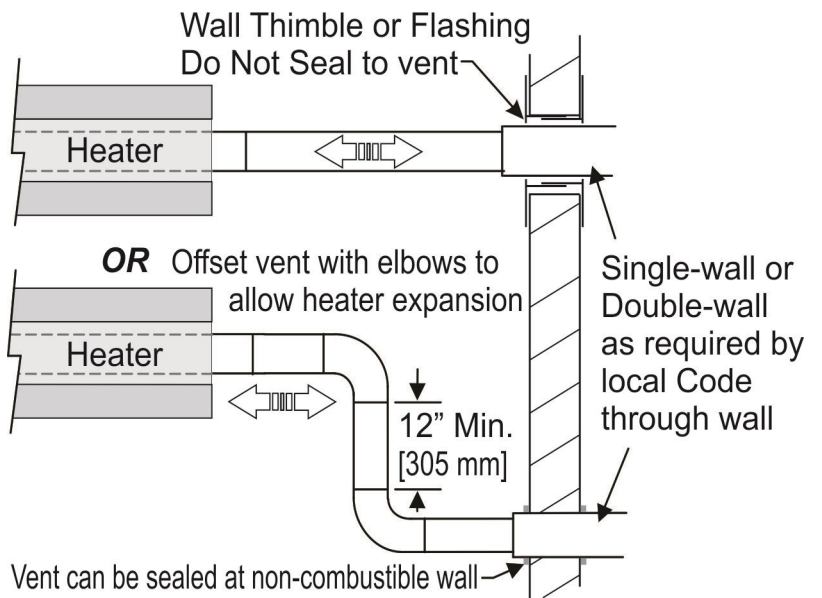

**COMMON VENTING**

For vertical vent only, two heaters can be commonly vented using 4"x 6"x 4" Vent Tee 902000008. Both heaters must be operated using one common thermostat. Common vent is 6 inch [150 mm] diameter.

Category III (horizontal vent) heaters cannot be common vented.



## **VERTICAL VENT THROUGH THE ROOF (CATEGORY I):**

It is the sole responsibility of the installer to adhere to all current local codes and/or ANSI Z223.1 latest editions for all venting requirements, and practices. Also adhere to instructions below, and the instructions of the vent manufacturer. Use vent materials certified for Category I.

All models of this series heater are certified Category I for vertical venting. See FIG. 5.

- The vent must extend at least 5 feet [1524 mm] above the flue collar of the highest connected heater
- USA: Horizontal run of single wall vent or vent connector (“H” in FIG 5) must not exceed 75% of the vertical height of the vent. If it does, then the vent system must be for Category III.
- Inputs up to 170,000 Btuh vertical vent can be 4” diameter Type B-Vent; greater than 170,000 Btuh must use 5” diameter Type B-Vent
- A vent connector must be secured to the flue collar using quantity 3 x #8 x 1/2” sheet metal screws
- A horizontal vent connector shall be installed and supported without any dips or sags and shall slope upward toward the vent or chimney at least 1/4 in./ft (20 mm/m).
- Use a certified termination cap as supplied by the manufacturer of the vent
- When vent and combustion air are taken through the roof, the exhaust vent should always terminate higher than the combustion air intake, to prevent recycling the products of combustion back into the heater
- The vent must extend at least 2 feet [610 mm] above the highest point where it passes through a roof. The vent must also extend at least two feet higher than any portion of a building within a horizontal distance of 10 feet [3 m].
- Keep vent connector runs as short as possible with a minimum number of elbows. Refer to the current edition of AN-SI Z223.1 (NFPA 54) installation codes for maximum length of horizontal vent and vent connector.
- Total length of the vent connector and vent pipe cannot exceed the values in Table 4 above.
- A single-wall vent connector shall not be insulated.
- For single-wall vent clearance to combustibles is 6" [152mm] except where a listed clearance thimble is used. Clearance to combustible material for Type B-Vent or factory-built vent per the vent manufacturer's instructions.

**FIGURE 7: VERTICAL VENT**

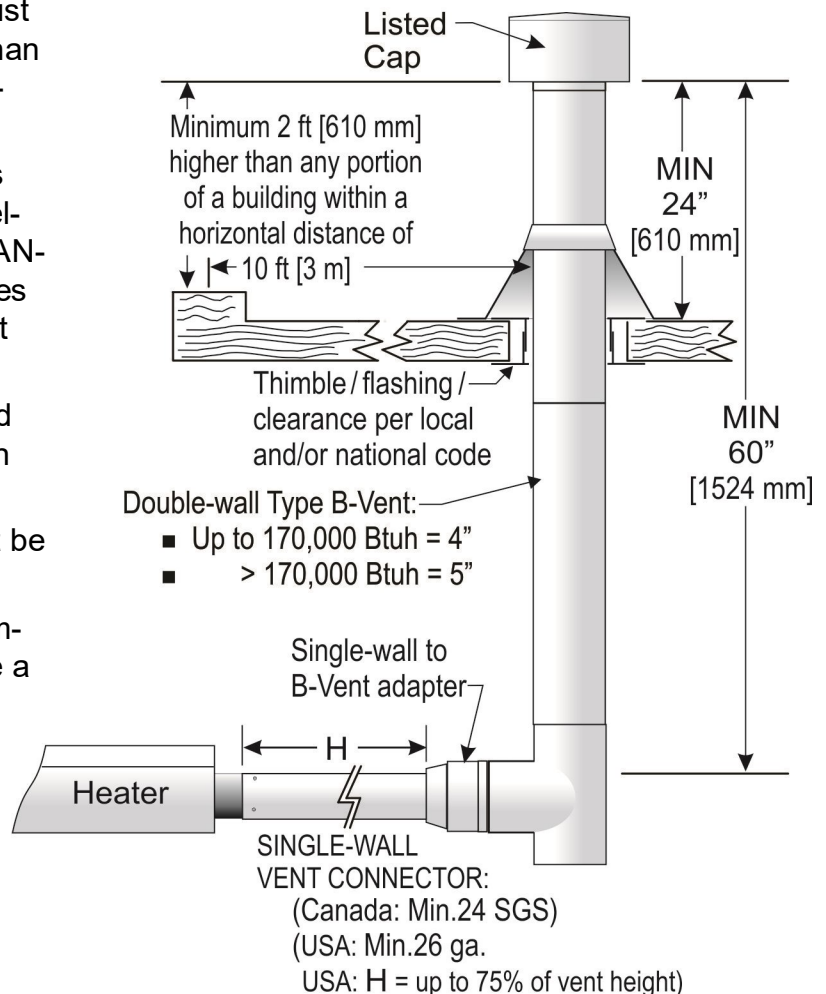

### **HORIZONTAL VENT THROUGH THE SIDEWALL (CATEGORY III):**

- When installed with a horizontal vent through a sidewall, this heater is a Category III appliance, and venting materials must be approved for Category III applications.
- All vent must be installed in accordance with local codes or, in the absence of local codes, with the *National Fuel Gas Code*, ANSI Z223.1/NFPA 54.
- All vent must installed in accordance with these instructions, and the instructions of the vent manufacturer.
- Do not mix vent components from different manufacturers in the vent system
- A single wall vent system may use a single continuous section of double wall vent pipe to pass through an exterior wall.
- Any horizontal portion of the flue vent system must slope downwards away from the heater a minimum of 1/4" per foot run [63 mm/ 300 mm] toward the vent terminal.
- All vent pipe from a single heater must be 4" [102 mm] diameter; common vent pipe for two heaters must increase to 6" [152 mm] at the point of connection of individual 4" vents
- Use approved 4" [102 mm] (902000002) or 6" [152 mm] (902000007) horizontal wall vent terminal or an approved high-wind termination cap
- Installation of the vent must prevent blockage by snow and protect building materials from degradation by flue gases.
- Install termination cap a minimum of 18 inches (45 cm) from the outside wall to the inside edge of terminal opening to alleviate back pressure caused by turbulent wind conditions (See Fig. 8). This also ensures flue gases are directed away from the structure to protect building materials from degradation by the exhausted flue gases.
- At most two 90° elbows can be installed in a horizontal vent
- A horizontal flue vent will not terminate less than 1 ft [30 cm] above grade level, unless its location is adjacent to public walkways, then it must not terminate less than 7 ft [2.1m] above the walkway.
- Clearance below a combustible overhang or soffit:
  - As indicated in FIGURE 8 for approved terminations: 4" [100 mm] 902000002 or 6" [150 mm] 902000000.
  - For other approved terminations: Will terminate 3 ft [915 mm] or more below a combustible soffit or overhang.
- A horizontal vent termination must be a minimum of 6 feet [1830 mm] from an inside corner formed by two exterior walls.
- A venting system shall be securely supported by noncombustible hangers suitable for the weight of the materials.
- A slip joint in the horizontal section of a venting system shall be secured with quantity 3 x #8 x 1/2" sheet metal screws to prevent sagging.
- Seal single-wall vent seams and joints with Dow Corning 736 Heat Resistant Sealant 600°F [315°C] or equivalent, or follow the instructions of the vent manufacturer for sealing vent pipe connections

USA specific requirements for horizontal vent are on the next page

**USA specific horizontal vent requirements:**

- The vent terminal of an appliance with an input up to 50,000 Btu/hr (14.7kW) shall be installed with a 9 inch [230mm] vent termination clearance from any air opening into a building, and an appliance with an input over 50,000 Btu/hr (14.7kW) shall have at least a 12 inch [305 mm] vent termination clearance. The bottom of the vent terminal and the air intake shall be located at least 12 inches [305 mm] above grade.
- A horizontal vent will not terminate:
  - Less than 3 ft [915 mm] above a mechanical air inlet located within 10 ft [3 m]
  - Less than 4 ft [1219 mm] below, 4 ft [1219 mm] horizontally from, and 1 ft [102 mm] above any window or door that opens, or gravity air inlet to a building
  - Less than 4 ft [1219 mm] horizontal clearance from gas and electric meters, regulators and relief equipment

**FIGURE 8: HORIZONTAL VENT THROUGH WALL**

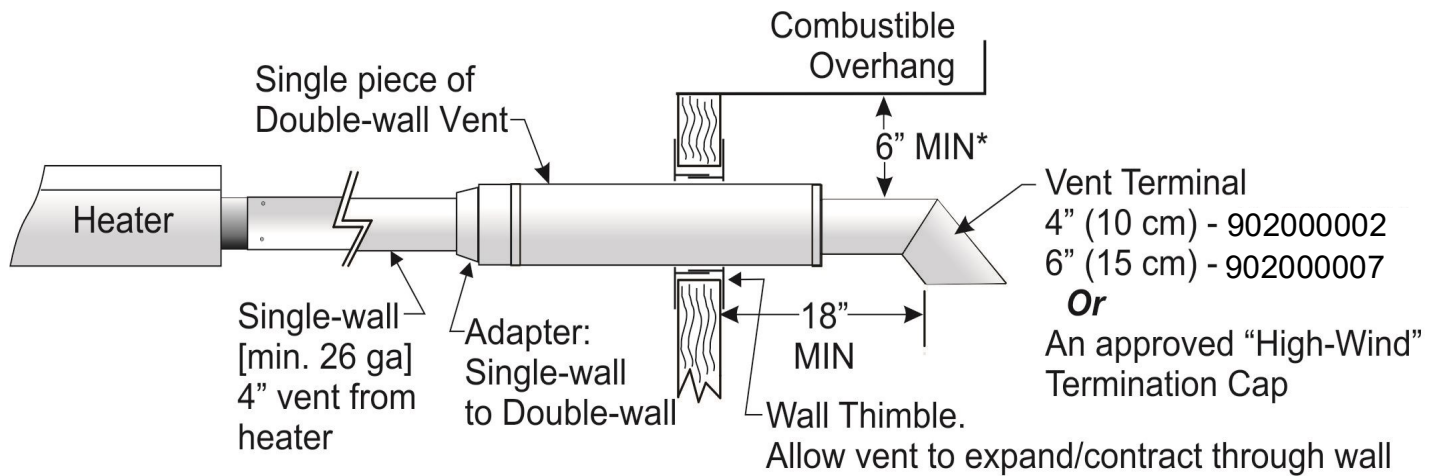

\* 6" Clearance Above applies to optional Vent Terminal:  
902000002 - 4" (10 cm); or 902000007 - 6" (15 cm)  
Use of alternate High-Wind terminal may require higher clearance. Refer to Vent Cap manufacturer's instructions.

## 6. GAS SUPPLY: MINIMUM / MAXIMUM & MANIFOLD PRESSURES

- Refer to General Manual for requirements on gas supply and flexible gas connection to the heater.

**TABLE 5 Manifold Pressure - Two Stage Models**

INPUT	FUEL TYPE	LINE PRESSURE		MANIFOLD PRESSURE (tap at gas valve outlet) INCHES WATER COLUMN
		INCHES WATER COLUMN MINIMUM	INCHES WATER COLUMN MAXIMUM	
TWO-STAGE	Natural Gas	5.0	14.0	3.5 / 2.0 (4.2 / 2.0 FOR 225&250 MBH)
	Propane	11.0	14.0	10.0 / 5.0

## 7. ELECTRICAL AND THERMOSTAT WIRING (WIRING DIAGRAMS NEXT PAGES)



### NOTICE

The heater must be electrically grounded in accordance with the National Electrical Code. ANSI / NFPA 70.

Appliance and control wiring must be in accordance with all applicable local codes. The total load of all heaters must be considered in determining the required contact rating of the controlling thermostat or switch. Each tube heater requires 120V, 60 HZ electrical power sized for 145VA. Maximum power flow for internal 24V burner components is 21VA.

The Fenwal ignition control includes a 24V/120V relay switch that provides a 45 second pre-purge and 45 second post-purge of the system. To maintain function of the post-purge feature, any **Thermostat / control must be installed in the thermostat circuit from the terminal block (TR - TW)**. A line voltage Thermostat or an "ON/OFF" control switch installed in the 120VAC power supply will disable the post-purge feature.

A maximum night set-back of 9°F (5°C) is recommended for optimum economy and comfort. To maintain satisfactory comfort levels do not turn off the heating system over night/weekends.

**8A. HE+ SERIES WIRING DIAGRAM: 24V OR 120 VOLT THERMOSTAT OPERATION**  
**SINGLE HEATER PER THERMOSTAT** *(Multiple Heaters per Thermostat—next page)*

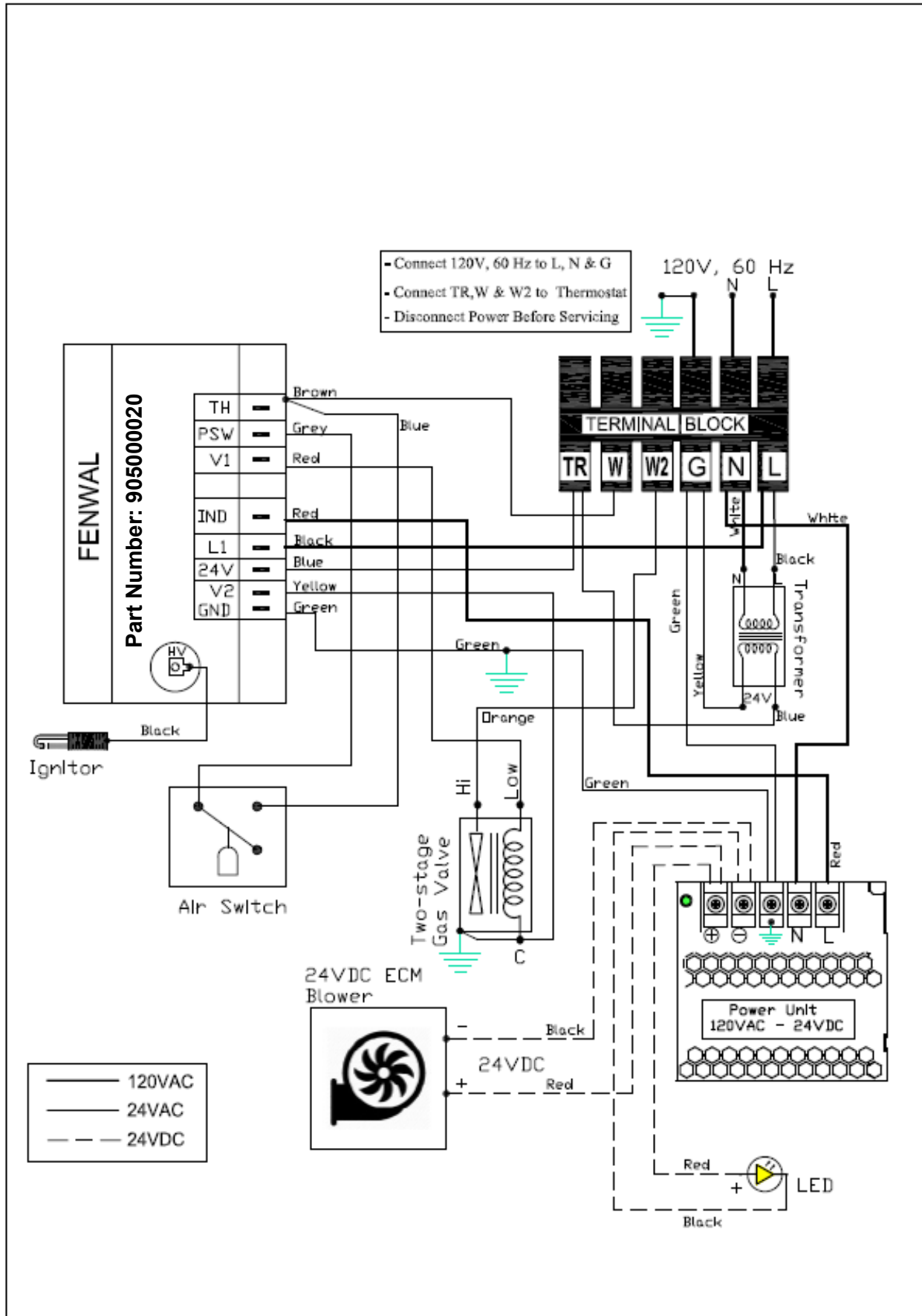



## 9. FENWAL DSI: SEQUENCE OF OPERATION / FLAME RECOVERY / SAFETY LOCKOUT

### Power Up / Stand By

Upon applying 24 volts power to 24VAC, the control will reset, perform a self check routine, initiate full time flame sensing, and enter the thermostat scan state.

### Heat Mode

When a call for heat is received from the thermostat supplying 24 volts to TH, the control checks the pressure switch for normally open contacts. The combustion blower is then energized and once the pressure switch contacts close, a 30 second purge delay begins. Following the purge period the gas valve is energized and spark commences for the 15 second trial for ignition.

When flame is detected during the trial for ignition, spark is shutoff immediately and the gas valve combustion blower remains energized. The thermostat, pressure switch, and main burner flame are constantly monitored to assure the system continues to operate properly. When the thermostat is satisfied and the demand for heat ends, the main valve is de-energized immediately, the control senses the loss of flame signal and initiates a 30 second post-purge period before de-energizing the combustion blower.

### Failure to Ignite - Lockout (THREE TRIAL MODEL)

This three-try control will attempt two additional ignition trials with a 30 second inter-purge between trials, before going into 'soft' lockout. The valve relay will be de-energized immediately, and the combustion blower will be turned off following the 30 second post purge period.

If the thermostat continues to call for heat after one hour the control will automatically reset and attempt to ignite the burner again (three trials).

At any time less than the 1 hour auto-reset, recovery from lockout requires a manual reset by either resetting the thermostat or removing 24 volts for a period of 5 seconds.

### Flame Failure - Re-cycle

If the established flame signal is lost while the burner is operating, the control will go to recycle mode. The HV spark will be energized for a trial ignition period in an attempt to relight the burner. If the burner does not light the control will de-energize the gas valve. Two more attempts will be made to relight the burner. If the burner does not relight the control will go into 'soft' lockout as noted above in "Failure to Light". If flame is re-established, normal operation resumes.

### Combustion Airflow Problems -Lockout

Combustion air flow is continually monitored during an ignition sequence by the air flow switch (PSW). If during the initial call for heat the pressure contacts are in the closed position for 30 seconds without an output to the Combustion Blower, an air flow fault will be declared and the control will remain in this mode with the combustion blower off.

If the air flow switch remains open for more than 30 seconds after the combustion blower output (L1 & IND) is energized, an air flow fault will be declared and the control will stay in this mode with the combustion blower on, waiting for the air flow switch to close.

When proper air flow is detected from the air flow switch input (PSW) the control begins the pre-purge period followed with a 15 second ignition sequence.

If the air flow signal is lost while the burner is firing, the control will immediately de-energize the gas valve and the combustion blower will remain on. If the call for heat remains, the control will wait for proper air flow to return. If proper air flow is not detected after 30 seconds an air flow fault signal will be declared. If proper air flow is detected at any time, a normal sequence will begin with the pre-purge period.

## Flame Fault

If at any time the main valve fails to close completely and maintains a flame, the full time flame sense circuit will detect it and energize the combustion blower. Should the main valve later close completely removing the flame signal, the combustion blower will power off following the optional post purge period.

## MOUNTING AND WIRING

The Fenwal DSI Control 24 VAC Tube Heater (905000020) is not position sensitive and can be mounted vertically or horizontally. The case may be mounted on any surface with #6 sheet metal screws. All wiring must be done in accordance with local and national electrical code. Refer to wire diagram page 35 when connecting 905000020 to other components in the burner.



## WARNING

The Fenwal DSI Control 24 VAC Tube Heater (905000020) uses voltages of shock hazard potential. Wiring and initial operation must be done by a qualified service technician. The control must be secured in an area that will experience a minimum of vibration and remain below the operating temperature of 160°F. All connections should be made with UL approved 105°C rated 18 gauge, stranded, .054 thick insulated wire. Refer to wire diagram page 35 when connecting the Series 35-61 to other components in the burner.

TERMI-NAL	SPADE	DESIGNATION
TH	1/4"	Thermostat Input
PSW	1/4"	Pressure Switch Input
V1	1/8"	Valve Power (MV)
IND	1/4"	Inducer Blower Output
NC	-	Alarm (Not used)
L1	1/4"	120/240 VAC Input (Hot)
24 VAC	1/4"	24 VAC Supply to Processor
V2	1/8"	Valve (MV)
GND	1/8"	Valve & System Ground
Spark	1/4"	Spark & Local Flame Sense

## CAUTION:

Label all wires prior to disconnection when servicing controls. Wiring errors can cause improper and dangerous operation. A functional checkout of a replacement control is recommended.

## PROPER ELECTRODE LOCATION

Proper location of the electrode assembly is important for optimum system performance. The electrode assembly should be located so that the spark gap is inside the flame envelope about 1 inch (2.5 cm) from the base of the flame at the burner cup.

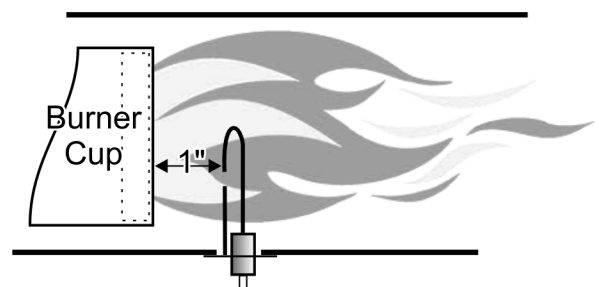

Electrodes should have a gap spacing of 3/16" (0.188" ± 0.031" or 4.76 mm ± 0.81 mm). If this spacing is not correct, the assembly must be adjusted or replaced. DO NOT adjust the curved igniter/sensor prong. Adjust/bend only the ground prong (also see next page).



## SPARK IGNITER SET UP

Use the following diagram to check the Igniter gap. If the gap is incorrect all adjustments should be made to the **GROUND PRONG/PIN ONLY! DO NOT BEND THE IGNITER PRONG!!!!**

**USE THE BLACK BARS BELOW AS A GUIDE FOR ADJUSTMENT. USE THE BARS THAT COINCIDE WITH THE FORMAT & SIZE OF THIS PUBLICATION .**

IF this manual is in

8.5" x 11" "booklet" format  
(pages folded in half)

3/16"

1/4"



then use these bars

OR

IF this manual is printed 8.5" x  
11" "full page" format

3/16"

1/4"



use these bars

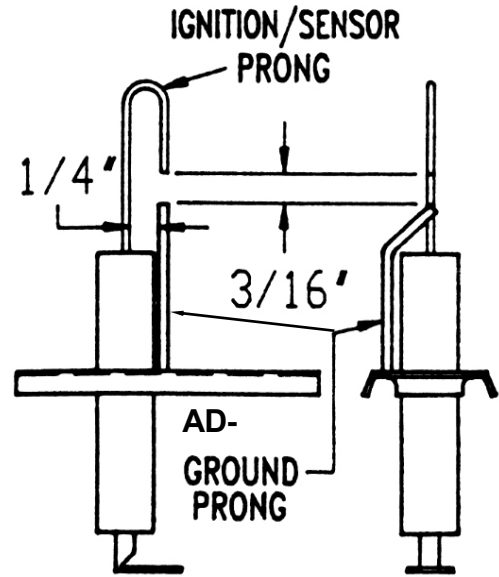

## SERVICE CHECKS

Flame current passes through the flame from the sensor to ground. The minimum flame current necessary to keep the system from lock-out is 0.7 microamps. To measure flame current, connect an analog DC microammeter to the FC- FC+ terminals per figure at right.

Meter should read 0.7  $\mu$ A or higher. If the meter reads below "0" on scale, meter leads are reversed. Disconnect power and reconnect meter leads for proper polarity.

Multipurpose Meter

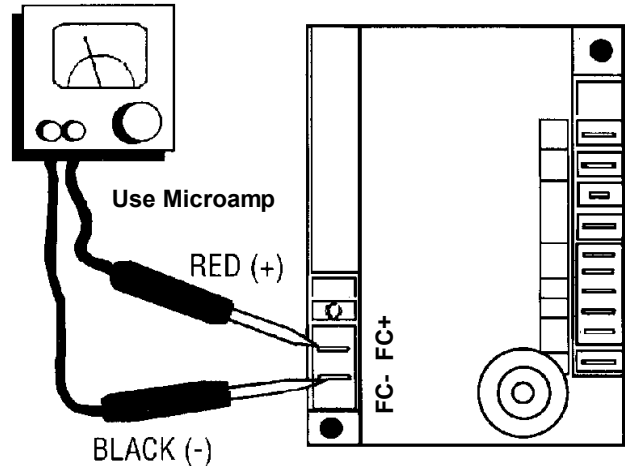

## 10. TROUBLESHOOTING GUIDE - FENWAL DSI

*(also see Heater Troubleshooting next page)*

SYMPTOM	RECOMMENDED ACTION(S)
<b>1. Dead</b>	<ul style="list-style-type: none"> <li>A. Miswired - check electrical supply (120Vac ± 5%)</li> <li>B. Transformer bad (24Vac ± 10%)</li> <li>C. Fuse/Circuit breaker bad</li> <li>D. Bad control (check LED for steady on)</li> <li>E. 24VDC Power Unit is bad</li> </ul>
<b>2. Thermostat on - no blower output</b>	<ul style="list-style-type: none"> <li>A. Miswired</li> <li>B. Bad thermostat no voltage @ terminal W</li> <li>C. Bad control (check LED for steady on)</li> <li>D. 24VDC Power Unit is bad</li> </ul>
<b>3. Pressure switch input okay, but no Trial-for- ignition after purge delay</b>	<ul style="list-style-type: none"> <li>A. Miswired (check PSW terminal voltage: 24Vac ± 10%)</li> <li>B. Flame sense problem (existing flame: check LED - 2 flashes)</li> <li>C. Bad control (check line voltage between L1 &amp; IND)</li> </ul>
<b>4. Valve on, no spark</b>	<ul style="list-style-type: none"> <li>A. Shorted electrode</li> <li>B. Open HV cable</li> <li>C. Bad control</li> </ul>
<b>5. Spark on, no valve</b>	<ul style="list-style-type: none"> <li>A. Valve coil open</li> <li>B. Open valve wire</li> <li>C. Bad control (check 24Vac voltage between V1 &amp; V2)</li> </ul>
<b>6. Flame ok during TFI, no flame sense (after TFI)</b>	<ul style="list-style-type: none"> <li>A. Bad electrode</li> <li>B. Bad HV igniter wire</li> <li>C. Poor ground at burner</li> <li>D. Poor flame (check flame current)</li> </ul>

## 11. TROUBLESHOOTING GUIDE - HEATER OPERATION



### WARNING

Improper adjustment, alteration, service or maintenance can cause property damage, injury or death. This heater must be installed and serviced only by a trained gas service technician

#### SEQUENCE OF EVENTS (also see *DSI Troubleshooting previous page*)

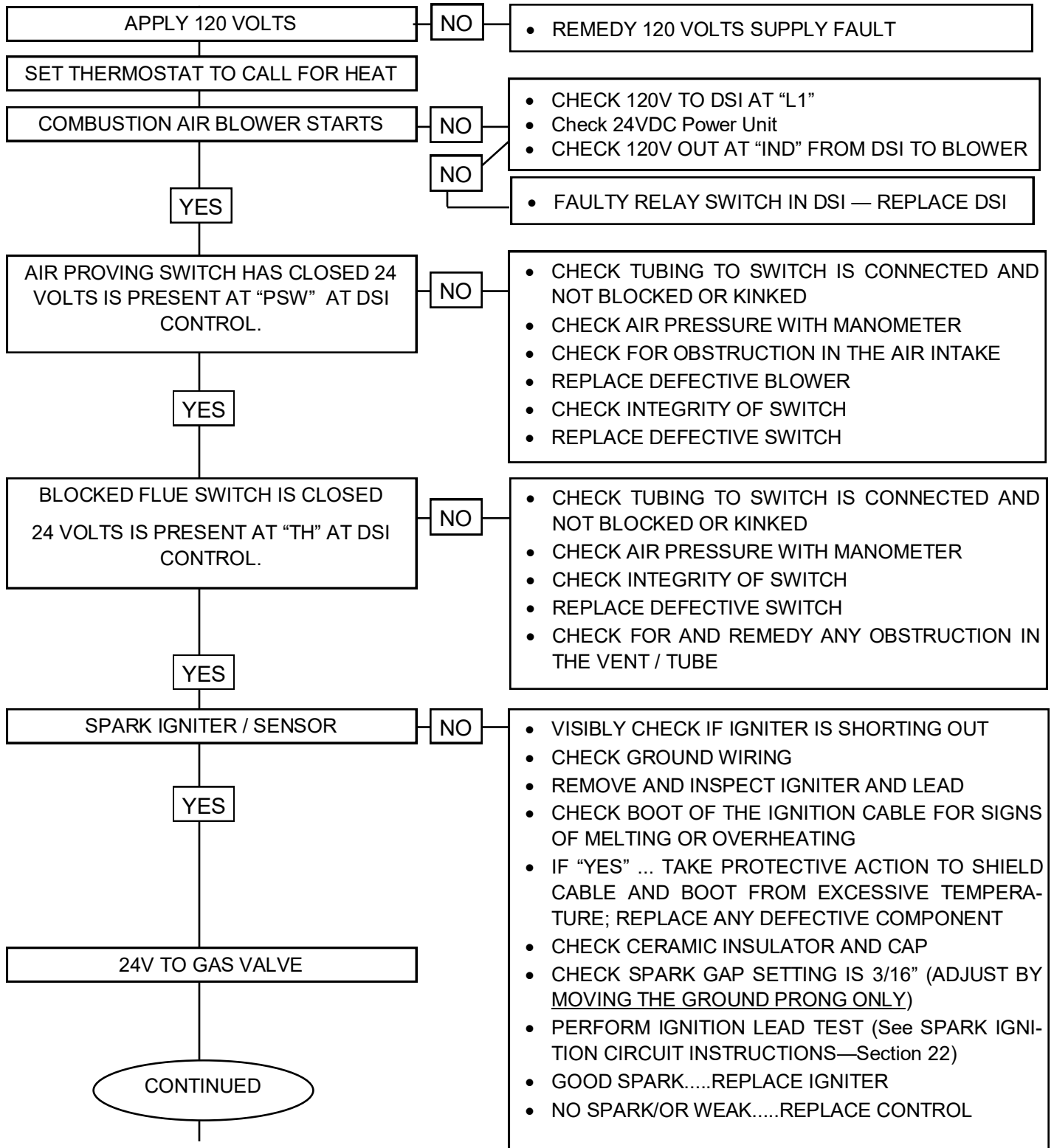

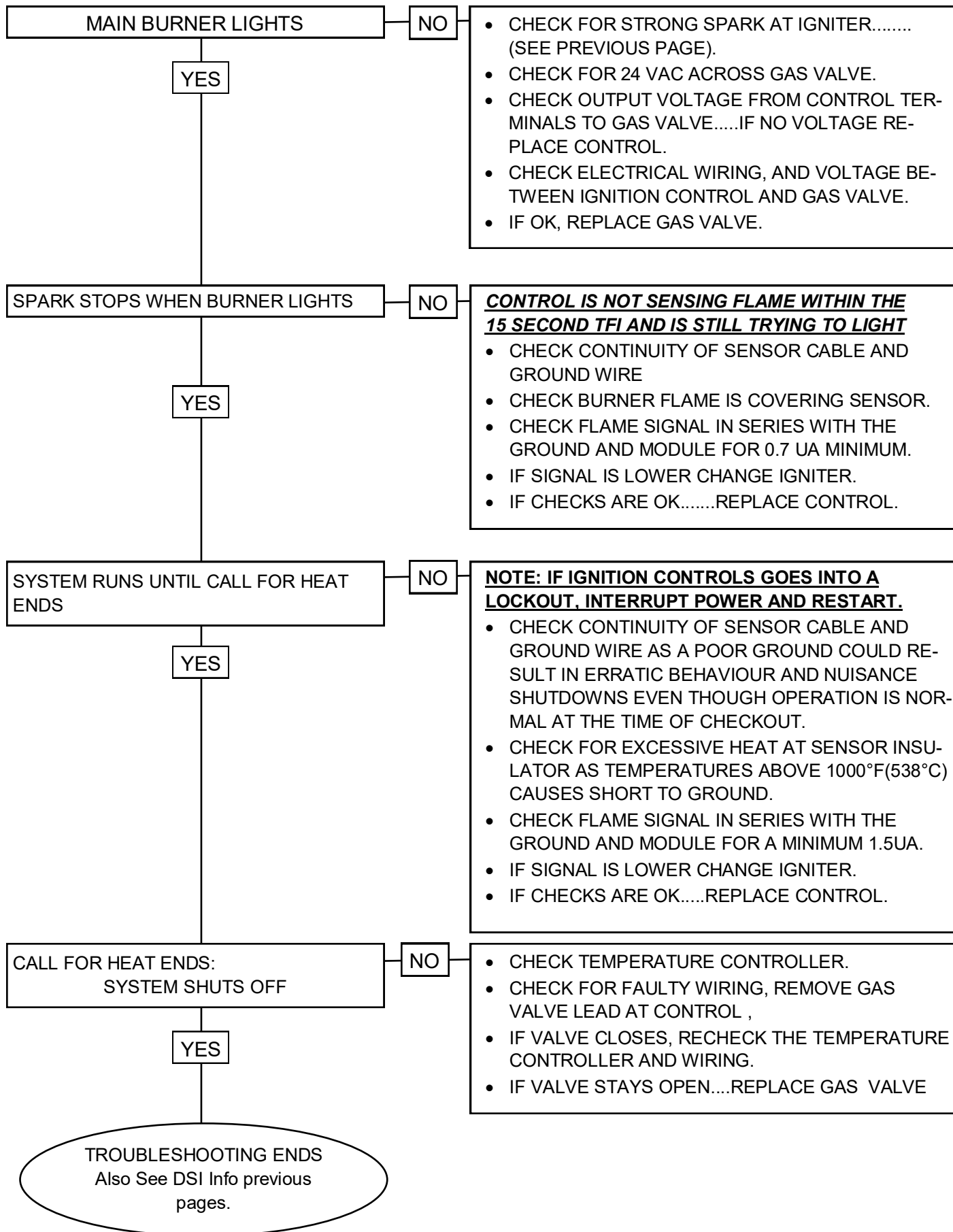

**12. START-UP / COMMISSIONING SHEET**



THIS EQUIPMENT HAS BEEN FACTORY FIRED AND TESTED PRIOR TO SHIPMENT. HOWEVER, THIS APPLIANCE IS NOT “PLUG & PLAY”. IT REQUIRES COMMISSIONING AND FIELD ADJUSTMENT / SPECIFICATIONS CONFIRMATION TO ENSURE SAFE AND EFFICIENT OPERATION.

**COMMISSIONING REPORT  
AS PER I&O MANUAL AND LOCAL CODES**

CONTRACTOR NAME: .....DATE.....

ADDRESS:.....  
.....

CITY:.....

PHONE:.....

CELL: .....

JOB SITE.....CITY.....

HEATER MODEL NUMBER:.....  
*Located on burner rating plate*

HEATER SERIAL NUMBER: .....

TO ENSURE THAT SITE CONDITIONS ARE COMPATIBLE WITH THE HEATER’S PERFORMANCE AND TO ALLEVIATE NUISANCE CALL-BACKS, THE FOLLOWING START-UP NEEDS TO BE COMPLETED BY THE QUALIFIED GAS INSTALLER.

---

 **WARNING**      **START UP ‘SMOKE’**

During start up, material coatings used in the production process of tubes and reflectors will “burn off” and create smoke during the first hour of operation. This is temporary and normal. Please ensure that there is sufficient ventilation to adequately clear the smoke from the space. Notify site and safety personnel to ensure that alarm systems are not unduly activated.

**QUALIFIED INSTALLER TO COMPLETE THIS**

TYPE OF GAS: NG  LP

DOES BUILDING HAVE A NEGATIVE CONDITION: YES  NO

IF THIS IS A HIGH ALTITUDE AREA WHAT IS THE ALTITUDE ABOVE SEA LEVEL  Ft

DOES APPLICATION REQUIRE FRESH AIR TO BURNER YES  NO

IS HEATER EXPOSED TO CHEMICAL OR CORROSIVE ATMOSPHERE: YES  NO

ARE ACTUAL MINIMUM CLEARANCES AS PER TABLE 3 YES  NO

CAN HEATER BE AFFECTED BY OVERHEAD CRANES / VIBRATION YES  NO

ARE GAS SUPPLY LINES ADEQUATELY SIZED FOR SYSTEM YES  NO

GAS LINES AND BRANCHES HAVE BEEN PURGED OF AIR: YES  NO

THIS HEATER FIRED WITHOUT ANY MALFUNCTION: YES  NO

INLET GAS SUPPLY PRESSURE WITH HEATER OPERATING :  WC"

GAS VALVE OUTLET (Manifold) PRESSURE WITH HEATER OPERATING:  WC"

WHAT IS THE LINE VOLTAGE READING AT THE HEATER  VOLTS

WHAT IS THE VOLTAGE READING AT THE IGNITION MODULE  VOLTS

WHAT IS THE FLAME SIGNAL STRENGTH IN uA FROM SENSOR:  uA (microamps)

IS HEATER CONTROLLED BY A THERMOSTAT YES  NO

IS THE THERMOSTAT STRATEGICALLY LOCATED YES  NO

WHAT IS TOTAL LENGTH OF INSTALLED THERMOSTAT WIRE  FEET

WHAT IS THE GAUGE OF THE THERMOSTAT WIRE  GAUGE

WHAT IS THE HEATER TUBE LENGTH (10ft per Tube section)  FEET

WHAT IS THE TOTAL LENGTH OF THE VENT (add 10ft for each bend)  FEET

WHAT LENGTH IS COMBUSTION AIR INTAKE (add 10ft for each bend)  FEET

IF REQUIRED....WHAT IS THE LENGTH OF THE TURBULATOR(S)  FEET

IF INSTALLED....IS TURBULATOR AT FLUE END OF SYSTEM YES  NO

"MAXIMUM STACKING HEIGHT" SIGN(S) - POSTED AT THERMOSTAT(S)

**THIS HEATER MUST BE ELECTRICALLY GOUNDED**

### **13. FIELD CONVERSION OF FUEL GAS: HE+ SERIES TWO-STAGE BURNERS**

Tube Heater Burners are factory produced and supplied to operate on natural gas.

A field conversion kit is available from Rinnai and must be used to convert from natural gas to propane gas, or vice versa. Each kit contains the required parts and specific instructions to make the gas conversion.

Refer to the table below for kit part numbers.

NOTE: All Kits include a Gas Orifice\*, and Valve Conversion Kit with Pressure Regulator Spring and Cap, and instructions to convert the gas valve and install the kit.

\* Gas Orifice in the Field Conversion Kit:

- USA: 0 to 2,000 ft
- Refer to “High Altitude” section for altitudes higher than listed above

**\*\* Call Factory for the Conversion Kit Part Number \*\***

## **14. HIGH ALTITUDE INSTALLATIONS - Refer to chart below for Restrictions**

When installed above the altitude stipulated below for USA, the input must be de-rated by 4% for each 1000 ft above the altitude listed. Refer to the tables below for orifice size and restrictions that apply to high altitude installation (including total system length restrictions). Check with your local utility regarding the gas supply and the de-rating of this appliance. Maintain gas supply pressure indicated in Section 4.

**USA:** The factory installed orifice for this appliance is approved for altitudes zero to 2000 feet above sea level.

### **14.A ORIFICE CONVERSION**

#### **Altitude Restrictions this Model:**

1. Do not install at altitudes greater than 8,500 ft
2. Restrict the length of any model to the shortest tube length at altitudes greater than 4,500 ft

When this appliance is installed above the altitude stipulated in the Table below, the input must be de-rated by 4% for each 1000 ft of altitude. **If your local utility supplies gas with a de-rated heat content, no orifice change is required in the heater** . Check with your local utility regarding de-rating, and the following specifically for country of installation.



**14. HIGH ALTITUDE INSTALLATION - ORIFICE TABLE ~ SEE NOTES ON PREVIOUS PAGE ~**

**RINNAI RECOMMENDED ORIFICES - ALTITUDE CONVERSION**

MODEL INPUT RATE (MBH)	FOR USE AT ALTITUDES ABOVE (FEET)							
	Gas Orifice Drill Size / Part#							
	Supplied	USA						
	0	2000	3000	4000	5000	6000	7000	8000
50 NG	#29 906000087	30 906000095	30 906000095	30 906000095	31 906000070	31 906000070	32 906000202	32 906000202
50 LPG	#46 906000088	46 906000088	47 906000212	47 906000212	47 906000212	48 906000213	48 906000213	49 906000071
65 NG	#23 906000089	25 906000197	25 906000197	25 906000197	27 906000198	27 906000198	29 906000087	29 906000199
65 LPG	#41 906000090	42 906000209	42 906000209	42 906000209	43 906000210	43 906000210	44 906000211	44 906000211
80 NG	#17 906000091	18 906000101	18 906000101	18 906000101	20 906000193	22 906000195	22 906000195	24 906000196
80 LPG	#37 906000092	38 906000206	38 906000206	39 906000207	40 906000208	40 906000208	42 906000209	42 906000209
115 NG	#2 906000093	3 906000172	3 906000172	5 906000173	6 906000174	8 906000176	8 906000176	10 906000188
115 LPG	#31 906000070	32 906000202	32 906000202	32 906000202	34 906000204	34 906000204	36 906000205	36 906000205
130 NG	1 906000094	A 906000171	A 906000171	2 906000093	4 906000124	4 906000124	7 906000175	7 906000175
130 LPG	#30 906000095	31 906000070	31 906000070	31 906000070	32 906000202	32 906000202	33 906000203	33 906000203
155 NG	G 906000096	F 906000181	F 906000181	F 906000181	D 906000180	B 906000178	B 906000178	1 906000094
155 LPG	#26 906000097	27 906000198	27 906000198	28 906000199	29 906000087	29 906000087	30 906000095	30 906000095
180 NG	M 906000098	K 906000184	K 906000184	K 906000184	J 906000183	H 906000182	H 906000182	F 906000217
180 LPG	#21 906000099	23 906000089	23 906000089	25 906000197	26 906000097	26 906000097	27 906000198	27 906000198
205 NG	R 906000100	P 906000102	P 906000102	P 906000102	N 906000186	N 906000186	M 906000098	M 906000098
205 LPG	18 906000101	20 906000193	20 906000193	21 906000099	23 906000089	23 906000089	25 906000197	25 906000197
225 NG	P 906000102	N 906000186	N 906000186	N 906000186	M 906000098	M 906000098	L 906000185	L 906000185
225 LPG	#16 906000190	18 906000191	18 906000191	18 906000191	19 906000192	19 906000192	20 906000194	20 906000194
250 NG	R 906000100	P 906000102	P 906000102	P 906000102	O 906000187	O 906000187	N 906000186	N 906000186
250 LPG	#14 906000104	16 906000103	17 906000091	17 906000091	18 906000101	19 906000128	19 906000128	19 906000128

## 15. REPLACEMENT PARTS: BURNER (Single-Stage and Two-Stage)

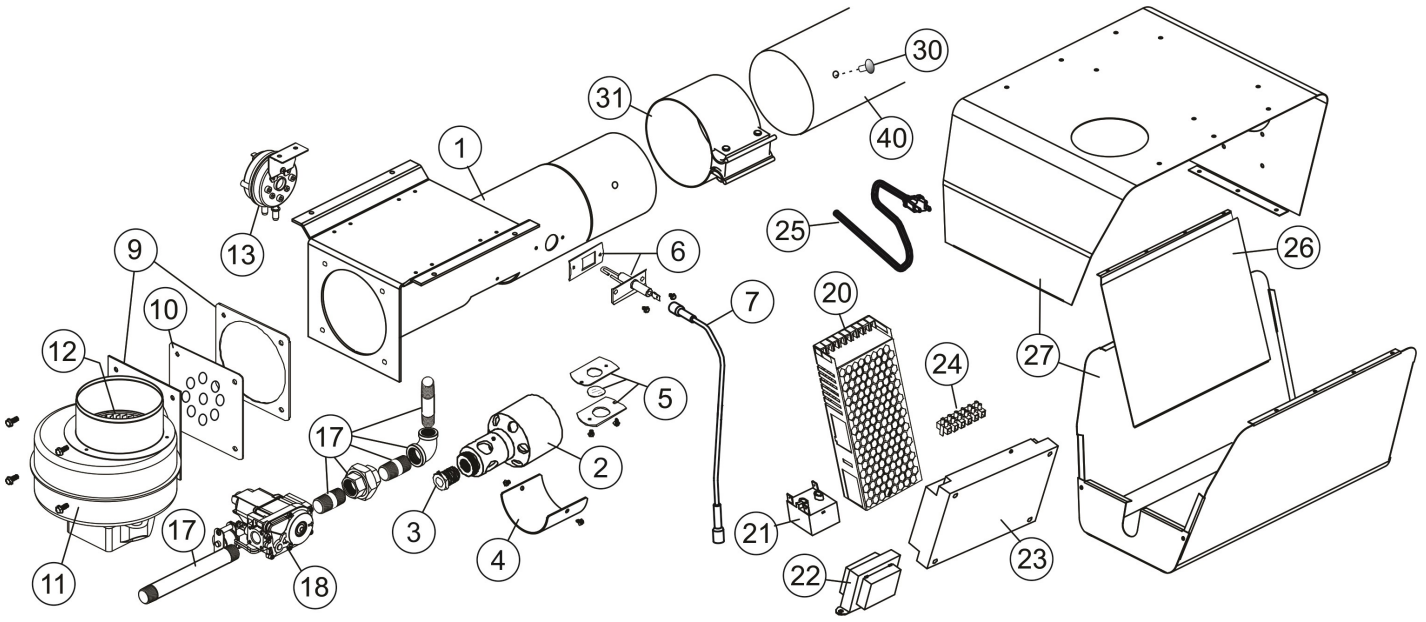

#	PART DESCRIPTION	MODEL (BTU)	GAS TYPE	PART #	PART DESCRIPTION PRIMARY
1	BURNER CHAMBER	ALL	NG; Propane	906000085	SSTM Burner Chamber
2	BURNER CUP	ALL	NG; Propane	906000086	SSTM Burner Cup - Steel
3	MAIN BURNER ORIFICE	50	NG	906000087	Gas orifice low intensity heater: 29 Number Size
			Propane	906000088	Gas orifice low intensity heater: 46 Number Size
		65	NG	906000089	Gas orifice low intensity heater: 23 Number Size
			Propane	906000090	Gas orifice low intensity heater: 41 Number Size
		80	NG	906000091	Gas orifice low intensity heater: 17 Number Size
			Propane	906000092	Gas orifice low intensity heater: 37 Number Size
		115	NG	906000093	Gas orifice low intensity heater: 2 Number Size
			Propane	906000070	Gas orifice low intensity heater: 31 Number Size
		130	NG	906000094	Gas orifice low intensity heater: 1 Number Size
			Propane	906000095	Gas orifice low intensity heater: 30 Number Size
		155	NG	906000096	Gas orifice low intensity heater: G Letter Size
			Propane	906000097	Gas orifice low intensity heater: 26 Number Size
		180	NG	906000098	Gas orifice low intensity heater: M Letter Size
			Propane	906000099	Gas orifice low intensity heater: 21 Number Size
		205	NG	906000100	Gas orifice low intensity heater: R Letter Size
			Propane	906000101	Gas orifice low intensity heater: 18 Number Size
		225	NG	906000102	Gas orifice low intensity heater: P Letter Size
			Propane	906000103	Gas orifice low intensity heater: 16 Number Size
		250	NG	906000100	Gas orifice low intensity heater: R Letter Size
			Propane	906000104	Gas orifice low intensity heater: 14 Number Size
4	BURNER CUP ACCESS CAP	ALL		906000105	Removable cap to access burner cup and orifice
5	SIGHT GLASS ASSEMBLY	ALL		909000118	Sight glass assembly - tube heater
6	IGNITER KIT	ALL		906000082	Igniter & gasket kit / DSI tube heater
7	IGNITION CABLE	ALL		905000050	Hi Voltage Wire-STW 2 x 1/4" Female Spade
9	BLOWER GASKET	ALL	Each	906000106	SST Blower Gasket

#	PART DESCRIPTION	MODEL (BTU)	MODEL DASH #/ GAS TYPE	PART #	PART DESCRIPTION PRIMARY
10	EQUALIZER PLATE	50	NG; Propane	906000107	Outlet equalizer plate 50
		65 & 80	NG; Propane	906000108	Outlet equalizer plate 65 & 80
		115 to 155	NG; Propane	906000109	Outlet equalizer plate 115, 130 & 155
		180	NG; Propane	906000110	Outlet equalizer plate 180
		205	NG; Propane	906000111	Outlet equalizer plate 205
		225 & 250	NG; Propane	906000109	Outlet equalizer plate 225 & 250
11	24 VDC BLOWER ASSEMBLIES	50 to 205	NG; Propane	908000014	24 VDC, 43W Blower Assembly - 50 to 205
		225 & 250	NG; Propane	908000015	24 VDC, 63W Blower Assembly - 225 & 250
12	BLOWER INTAKE RESTRICTOR	50 & 65	NG; Propane	908000016	Blower Air Intake Restrictor: 1.25 inch Hole
		130	NG; Propane	908000017	Blower Air Intake Restrictor: 1.5 inch Hole
		80 & 115	NG; Propane	908000018	Blower Air Intake Restrictor: 1.75 inch Hole
		155	NG; Propane	908000019	Blower Air Intake Restrictor: 2.75 inch Hole
		180 & 205	NG; Propane	908000020	Blower Air Intake Restrictor: 3.625 inch Hole
		225 & 250	NG; Propane	908000019	Blower Air Intake Restrictor: 2.75 inch Hole
13	AIR PRESSURE SWITCH	50	NG; Propane	905000029	Air proving Switch 1.30" WC
		65	NG; Propane	905000030	Air proving Switch 1.15" WC
		80	NG; Propane	905000031	Air proving Switch 1.40" WC
		115 to 205	NG; Propane	905000032	Air proving Switch 0.70" WC
		225 & 250	NG; Propane	905000030	Air proving Switch 1.15" WC
17	GAS TRAIN PIPING	ALL		Customer-Supplied	1/2" x Pipe Nipples, Union and Elbow
18	GAS VALVE - SINGLE STAGE	50 to 155	NG	906000078	Valve gas comb 3.5" WC 24VAC VR8 NG
		50 to 155	Propane	906000079	Valve gas comb 10" WC 24VAC VR8 LP
		180 to 250	NG	906000112	Gas Valve - Slow Open 3.5" WC NG
		180 to 250	Propane	906000113	Gas Valve - Slow Open 10" WC LP
	GAS VALVE - TWO-STAGE	ALL	NG Only	906000114	Gas Valve Two-stage- Slow Open -3.5"/2.2" ( VR8205)
20	120VAC to 24VDC POWER SUPPLY	50 to 205	NG; Propane	905000033	120VAC to 24VDC Power Supply, 50 to 205
		225 & 250	NG; Propane	905000034	120VAC to 24VDC Power Supply, 225 & 250
21	RELAY SWITCH: 2-STAGE LO/HI INPUT	ALL		905000035	Thermostat Relay- 24V
22	STEP DOWN TRANSFORMER	ALL		905000019	Transformer 120/24V, 20VA AT120B1028
23	FENWAL DSI CONTROL	ALL		905000020	3-Trial 24Vac with blower relay
24	TERMINAL BLOCK	ALL	Each	905000018	Terminal block (2)
25	ELECTRICAL CORD	ALL		905000028	Cord - electrical 6'
26	COMPONENT PLATE	ALL		909000121	Component mounting plate SST- Flat
27	BURNER HOUSING	ALL		906000115	Burner housing coated black
30	STAINLESS STEEL RIVET 1/4"	ALL	Each	906000116	1/4" Stainless Steel Rivet
31	COUPLER	ALL		906000117	4" swaged tube coupler torctite

## 16. REPLACEMENT PARTS: TUBE SYSTEM HE+ SERIES

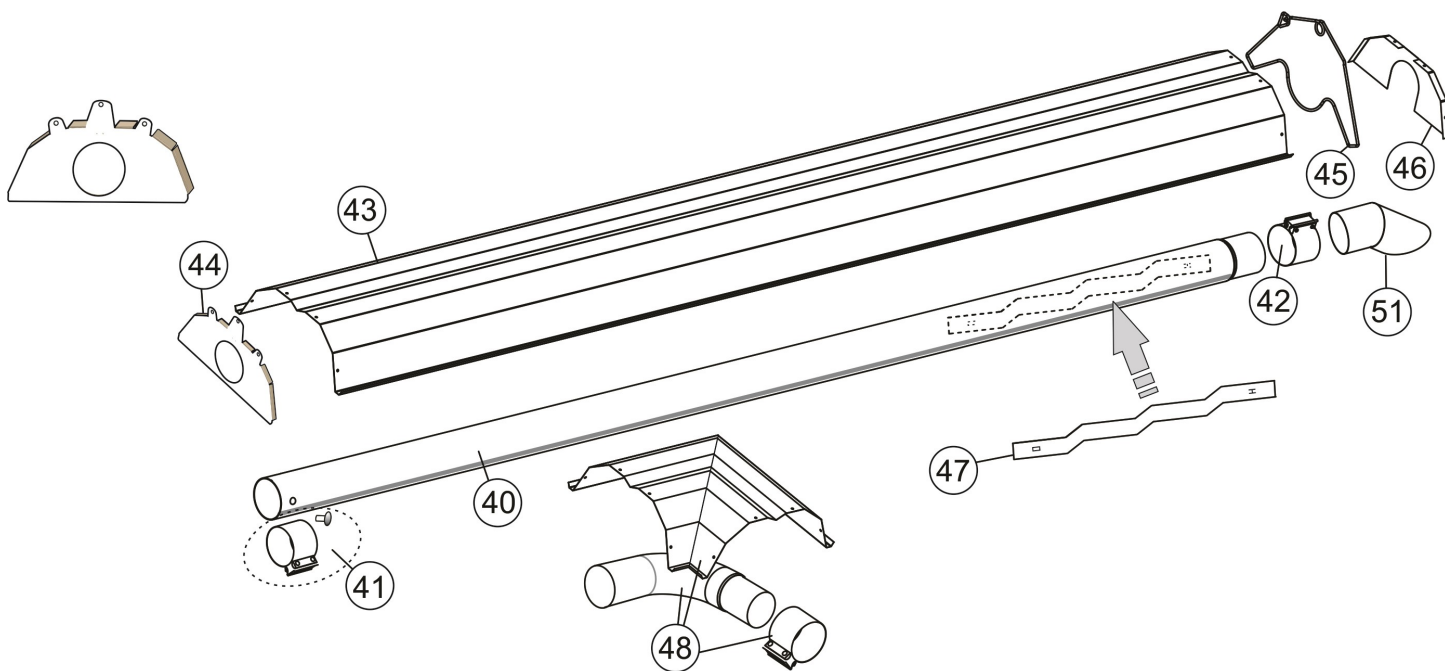

#	PART DESCRIPTION	MODEL (BTU)	NOTE	PART #	PART DESCRIPTION PRIMARY
40	SYSTEM TUBES:				
	PRIMARY COMBUSTION TUBE	50 to 205		906000118	Aluminized Steel Tube with Holes + Rivet + Coupler
		225 to 250		906000119	Stainless Steel Tube with Holes + Rivet + Coupler
	HEAT EXCHANGER TUBES	ALL		906000120	Coated Steel Tube; 10 ft with swage
		50 to 205	Second Tube	906000120	Coated Steel Tube; 10 ft with swage
		225 to 250	Second Tube	906000119	Stainless Steel Tube with Holes + Rivet + Coupler
41	STAINLESS STEEL COUPLER + STAINLESS STEEL RIVET	225 to 250	1st to 2nd & 2nd to 3rd tube connections	906000121	Tube Connection Kit: Coupler + Rivet (225 to 250: 1st to 2nd & 2nd to 3rd tube)
42	COUPLER - Aluminized Steel	ALL		906000117	4" swaged tube coupler torcite
43	REFLECTOR	STRAIGHT		909000122	Single Tube Reflector x 120"
44	PLATE HANGER - BURNER END ONLY	ALL	Burner End ONLY	909000123	Single Tube Plate Hanger (Burner End)
45	WIRE HANGER: TUBE / REFLECTOR	STRAIGHT		909000124	Wire Hanger
46	REFLECTOR END CAP: SINGLE TUBE	STRAIGHT	Vent End ONLY	909000125	Reflector end cap: Single tube
47	TURBULATOR	ALL	Refer to Table in Manual	906000122	Turbulator 2.25" x 36"
48	90° ELBOW KIT	ALL	OPTIONAL	906000123	90° elbow + Coupler + Reflector Cover
51	HORIZONTAL VENT TERMINATION	ALL	OPTIONAL	902000002	4" horizontal wall vent terminal

## NOTES

## NOTES

## NOTES

# Rinnai America Corporation

103 International Drive  
Peachtree City, GA 30269  
Tel. 1-800-621-9419  
Web. [www.rinnai.us](http://www.rinnai.us)  
[www.rinnai.ca](http://www.rinnai.ca)

900000015(01)  
4/2021